

Operating Manual

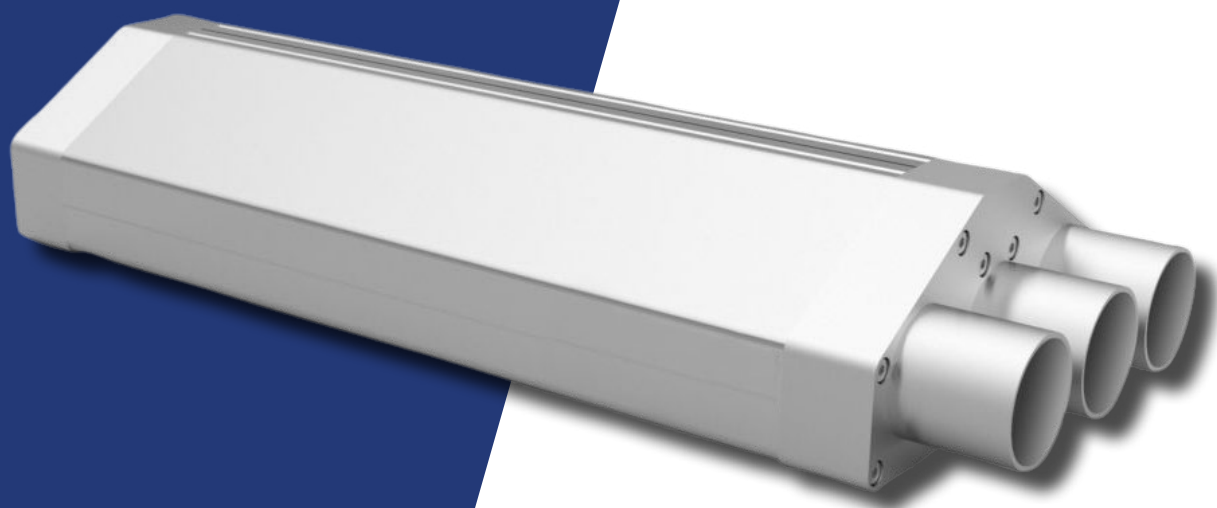

CyClean-R™
Non-Contact Web Cleaning

Contents

| | | |
|--------|---|----|
| 1. | Safety Instructions | 1 |
| 1.1. | General Safety..... | 1 |
| 1.2. | Electrical Safety..... | 1 |
| 1.3. | Warning and Information Labels..... | 2 |
| 2. | What is Included | 3 |
| 3. | Removing CyClean-R | 4 |
| 4. | CyClean-R System Overview | 4 |
| 4.1. | Function | 4 |
| 5. | Installation Procedure | 5 |
| 5.1. | CyClean-R Configurations..... | 5 |
| 5.2. | Suggested Order of Installation | 9 |
| 5.3. | Mounting the CyClean-R..... | 9 |
| 5.3.1. | Positioning of the System | 9 |
| 5.3.2. | Web Direction and Tension | 9 |
| 5.3.3. | General Mounting Instruction | 10 |
| 5.3.4. | Fixed CyClean-R | 11 |
| 5.3.5. | Fixed Carapace CyClean-R..... | 11 |
| 5.3.6. | Pneumatic CyClean-R..... | 12 |
| 5.3.7. | Pneumatic CyClean-R Carapace | 12 |
| 5.4. | Pneumatic Connection..... | 13 |
| 5.5. | Positioning of 924IPS Bars..... | 16 |
| 5.5.1. | Electrical Installation..... | 17 |
| 5.6. | Connecting to Power Supply | 18 |
| 5.6.1. | Connecting to Meech Power Supply | 18 |
| 5.6.2. | Connecting to Customer’s Power Supply | 18 |
| 5.7. | Ducting..... | 19 |
| 5.7.1. | Ducting Kits..... | 19 |
| 5.7.2. | Connecting the Ducting | 19 |
| 5.7.3. | Securing the Ducting..... | 20 |
| 6. | Operating the CyClean-R..... | 21 |
| 6.1. | Before Use..... | 21 |
| 6.2. | System Setup..... | 21 |
| 6.3. | Pneumatic CyClean-R..... | 22 |
| 6.4. | Commissioning..... | 25 |
| 6.4.1. | Initial Setup..... | 25 |
| 7. | Troubleshooting | 26 |
| 8. | Maintenance & Inspection..... | 26 |
| 8.1. | Inspection | 26 |
| 8.2. | Maintenance..... | 27 |
| 9. | Spare Parts | 28 |
| 10. | Technical Specification | 28 |
| 11. | Repairs & Warranty..... | 28 |
| 12. | Technical Drawings..... | 29 |

Products shown in this document may be covered by one or more patents, patents applied for and/or registered designs and/or trademarks. For further information, please refer to our head office or visit www.meech.com.

1. Safety Instructions

Before using equipment, read the following safety and operating instructions to ensure your own personal safety and help to protect your equipment. Failure to do so could result in injury or death. Connected equipment may require additional safety instructions. Observe all safety instructions for additional equipment connected before operating.

1.1. General Safety

Before setting up the equipment:

- Read the operating instructions carefully and ensure you understand how to use the equipment correctly.
- Installation and testing must only be completed by those suitably qualified.
- Inspect the working environment and ensure it is clean and clear of hazards before removing equipment from packaging and positioning the system.
- Visually check all equipment for damage. If damaged, contact your local Meech representative before continuing.
- Observe warning symbols placed on the equipment, see page 2.
- Ensure a minimum distance of at 0.5m is kept around the Air Handling Unit (AHU) to permit adequate airflow required for ventilation. Restricting airflow may damage the equipment.
- Keep all cables secured until ready for use.
- Keep a copy of the Operating Manual close to the system at all times.









1.2. Electrical Safety

Before installing, performing repairs or maintenance on equipment, ensure the system is electrically isolated. Failure of this could result in injury or death.



Before working on the equipment:

- Check the equipment is electrically isolated correctly.
- Check equipment and cables for damage. If damaged, contact your local Meech representative before continuing.
- Ensure all wiring is completed by competent personnel.
- Check all connections in relation to the wiring diagram.

1.3. Warning and Information Labels

| Label/Symbol | Position |
|---|--|
|  | <p>Danger Mains Voltage sign indicates an immediate hazard. If not avoided, this will result in death or serious injury.</p> |
|  | <p>Caution - Hot sign indicates a potential hazard if not avoided, this will result in minor or moderate injury.</p> |
|  | <p>Warning – Do not cover sign indicates a potential hazard if not avoided, which will result in damage of equipment.</p> |
|  | <p>Caution – Crush Hazard sign indicates a potential hazard if not avoided, this will result in minor or moderate injury.</p> |
|  | <p>Information – Web Entry sign indicates the direction of which the web material needs to enter the system.</p> |
|  | <p>Information – Web Exit sign indicates the direction of which the web material needs to exit the system.</p> |
|  | <p>Information – Vacuum Airflow sign indicates the direction of airflow through the system.</p> |
|  | <p>Information – Positive Airflow sign indicates the direction of airflow through the system.</p> |

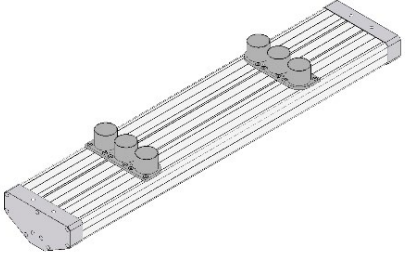
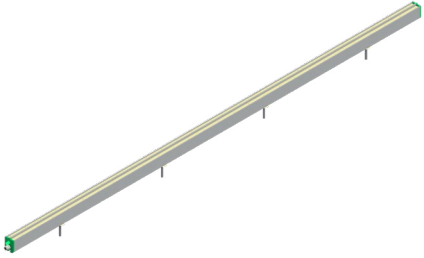
2. What is Included:

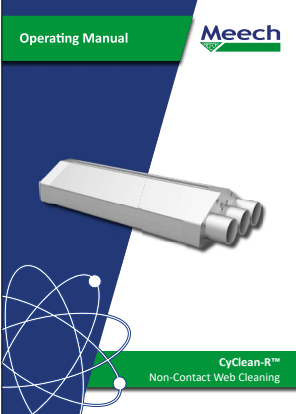
| Image | Description |
|---|--|
|  | <p>CyClean-R Manifold</p> |
|  | <p>924IPS Pulsed DC Bar (x2 per Manifold)* <i>*924IPS Cables <u>not</u> included. These can be purchased separately.</i></p> |
|  | <p>Air Handling Unit (AHU)</p> |
|  | <p>Operating Manual</p> |

3. Removing CyClean-R

1. Remove lid from manifold crate

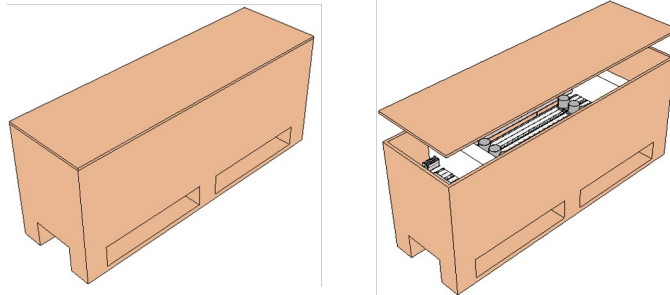

2. Carefully remove the CyClean-R from the manifold crate

CAUTION

Remove the CyClean-R by the foam packing blocks, containing the CyClean-R manifold and 2x 924IPS Bars. This will help to protect the equipment. Do not remove from foam protection until ready to install.

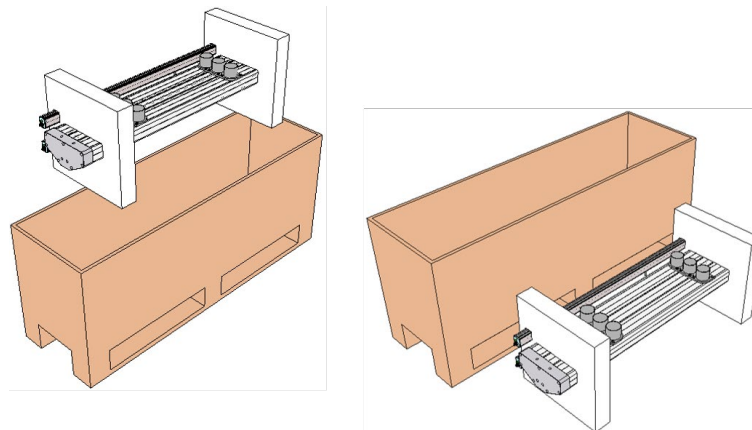

4. CyClean-R System Overview

4.1. Function

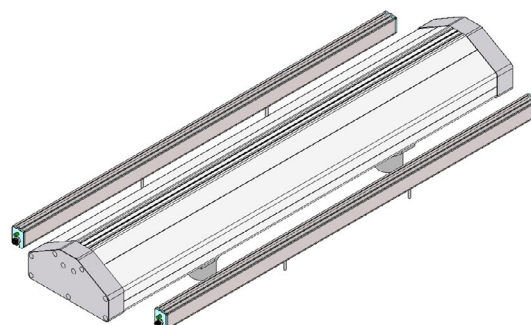

The CyClean-R is a non-contact web cleaning system that can be used on web that sits around a roller, designed for webs running low tension and can be used with wide variety of web materials.

CyClean-R is available as both a single-sided and double-sided cleaning configuration. To use the system in a double-sided configuration, it must be positioned over two separate rollers.

CyClean-R delivers consistent removal of dry, unbonded contamination from the web surface (particle removal to 0.5 micron is achievable), with assistance from the included 924IPS Bars.

5. Installation Procedure

CAUTION

Meech CyClean-R web cleaning systems should only be used in installations for which they are designed. If the CyClean-R is used in any other way than instructed in this manual, it will be considered improper use.

5.1. CyClean-R Configurations

IMPORTANT

Carefully read the installation instruction relevant to the CyClean-R system before installation. Ensure you have a full understanding of the procedure before beginning work.

The table below outlines the configurations available, including the opening types, ducting, static control and the AHU required for each. The opening configurations can be seen on page 6 - 8, for reference.

| Product Code | Width | Web Width (mm) | Opening | | Ducting | Qty of 924IPS Bars | AHU |
|-------------------|--------|-----------------|---------|------------------|----------------------------|--------------------|---------------|
| | | | Fixed | Pneumatic Option | | | |
| ACR-0200-ACR-0600 | Narrow | 200mm - 699mm | ✓ | ✓ | End, Top or Rigid feed | 2 | AHUv3 1.1 |
| ACR-0700-ACR-1200 | Mid | 700mm - 1299mm | ✓ | ✓ | 2x End feed or 2x Top feed | 2 | AHUv3 2.2 |
| ACR-1300-ACR-2300 | Wide | 1300mm - 2399mm | ✓ | ✓ | End feed-added carapace | 2 | AHUv3 3.3 |
| ACR-2400-ACR-3900 | | 2400mm - 3999mm | ✓ | ✓ | End feed-added carapace | 2 | AHUv3 6.6 |
| ACR-4000 | | 4000+mm | ✓ | Special design | End feed-added carapace | 4 | AHUv3 6.6&3.3 |

*For web widths up to 600mm, a ducting kit up to 3m can be supplied. It is not recommended this length is exceeded when using Ø40mm ducting due to airflow restrictions.

For lengths up to 600mm, CyClean-R can be either fixed or pneumatic to facilitate fast and accurate webbing-up.

On web-widths over 1300mm, CyClean-R is supplied with a carapace. The carapace provides the necessary rigidity for wide web applications, while also offering an ergonomic design.

Systems greater than 4001mm are installed rigidly on the machine. On these systems, a custom design will be used on the mechanism to web-up.

Narrow Web : Fixed End-Feed

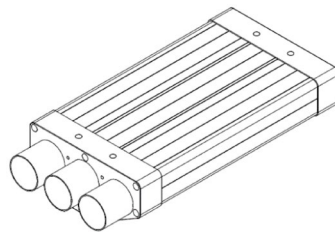

| | |
|---------------|--------------|
| System Design | Fixed |
| Ducting Feed | End-Feed |
| Width Range | 200mm- 699mm |
| Opening range | N/A |

Narrow Web : Fixed Tab-Feed

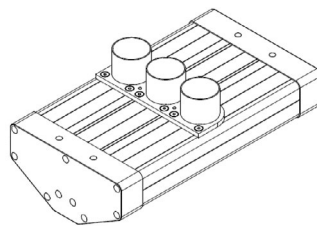

| | |
|---------------|---------------|
| System Design | Fixed |
| Ducting Feed | TAB-Feed |
| Width Range | 200mm – 699mm |
| Opening Range | N/A |

Narrow Web : Pneumatic End-Feed

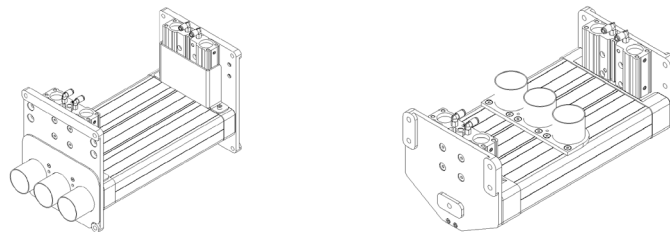

| | |
|---------------|--------------|
| System Design | Pneumatic |
| Ducting Feed | 1 x End Feed |
| Width Range | 200mm-699mm |
| Opening Range | 0mm-30mm |

Narrow Web : Pneumatic Tab-Feed

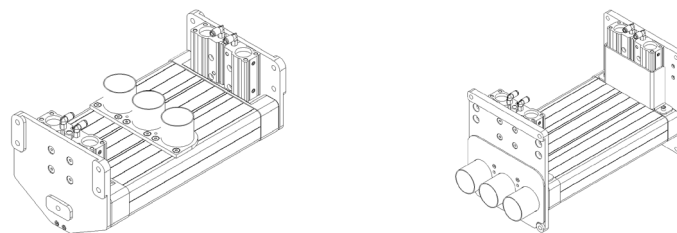

| | |
|---------------|--------------|
| System Design | Pneumatic |
| Ducting Feed | 1 x Top Feed |
| Width Range | 200mm-699mm |
| Opening Range | 0mm-30mm |

Mid Web : Fixed End-Feed

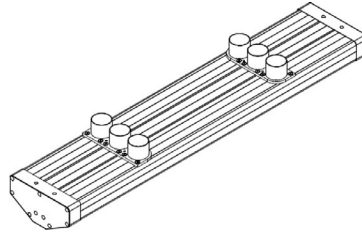

| | |
|---------------|--------------|
| System Design | Fixed |
| Ducting Feed | 2x End-Feed |
| Width Range | 700mm-1299mm |
| Opening Range | N/A |

Mid Web : Fixed Tab-Feed

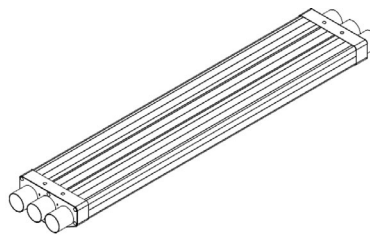

| | |
|---------------|--------------|
| System Design | Fixed |
| Ducting Feed | 2x Top-Feed |
| Width Range | 700mm-1299mm |
| Opening Range | N/A |

Mid Web : Pneumatic Tab-Feed

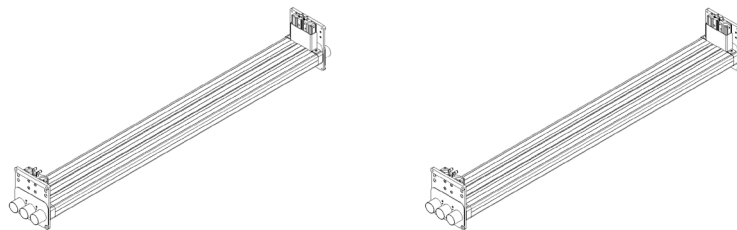

| | |
|---------------|--------------|
| System Design | Pneumatic |
| Ducting Feed | 2 x End Feed |
| Width Range | 700mm-1299mm |
| Opening Range | 0mm-30mm |

Mid Web : Pneumatic Tab-Feed

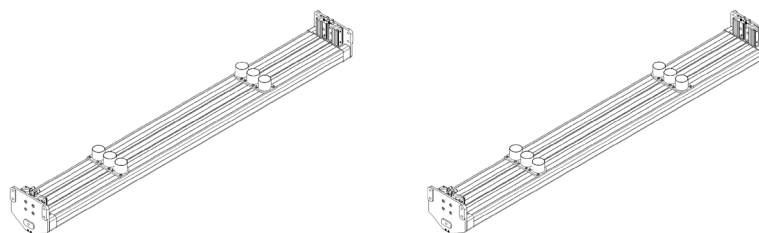

| | |
|---------------|--------------|
| System Design | Pneumatic |
| Ducting Feed | 2 x Top Feed |
| Width Range | 700mm-1299mm |
| Opening Range | 0mm-30mm |

Wide Web : Fixed

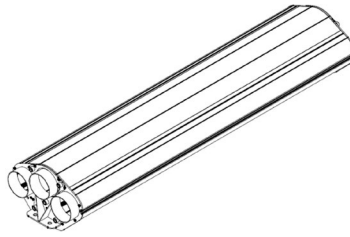

| | |
|---------------|---|
| System Design | Fixed with carapace, for enhanced rigidity at larger widths |
| Ducting Feed | Ducting Feed End-Feed |
| Width Range | Width Range 1300mm- 4000mm |
| Opening Range | N/A |

Wide Web : Pneumatic

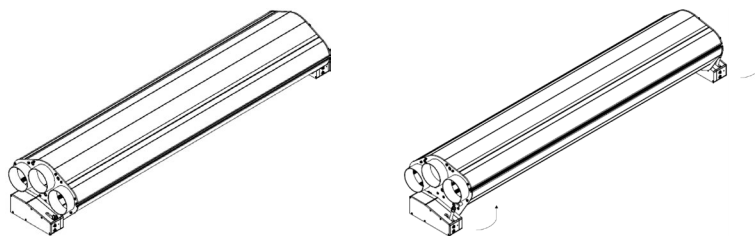

| | |
|---------------|--|
| System Design | Pneumatic tilt opening with carapace, for enhanced rigidity at larger widths |
| Ducting Feed | End-Feed |
| Width Range | 1300mm-4000mm |
| Opening Range | 18mm |

5.2. Suggested Order of Installation

For ease of installation, it is recommended that the system components be installed in the following order:

1. Position and mount the head unit (the manifold should be positioned between 1-3mm above the web).
2. Position and mount the Air Handling Unit (in a well ventilated area to avoid overheating and considering the available ducting lengths).
3. Make all the electrical connections.
4. Make all compressed air connections (if required).
5. Connect all ducting and secure using clips.

5.3. Mounting the CyClean-R

5.3.1. Positioning of the System

The CyClean-R head unit is installed over the apex of a guide roller and can be positioned at any angle without jeopardising cleaning performance.

In general, the CyClean-R system should be installed as close to the critical process as possible to minimise the potential of re-contaminating the web via airborne contamination. Meech would recommend between 1-3mm over the web; however, this may differ depending on the application. Where a double-sided configuration is required the CyClean-R heads will be installed at different stages of the web.

5.3.2. Web Direction and Tension

In applications where high web tension is not possible, a CyClean-R is ideal, as it uses the tension resulting from the web wrapping around a roller to provide a stable cleaning surface and prevent the web from being pulled into the CyClean-R by its powerful airflows

The CyClean-R should only be mounted in the orientation it was designed. See the diagram below showing the pip on the CyClean-R extrusion.

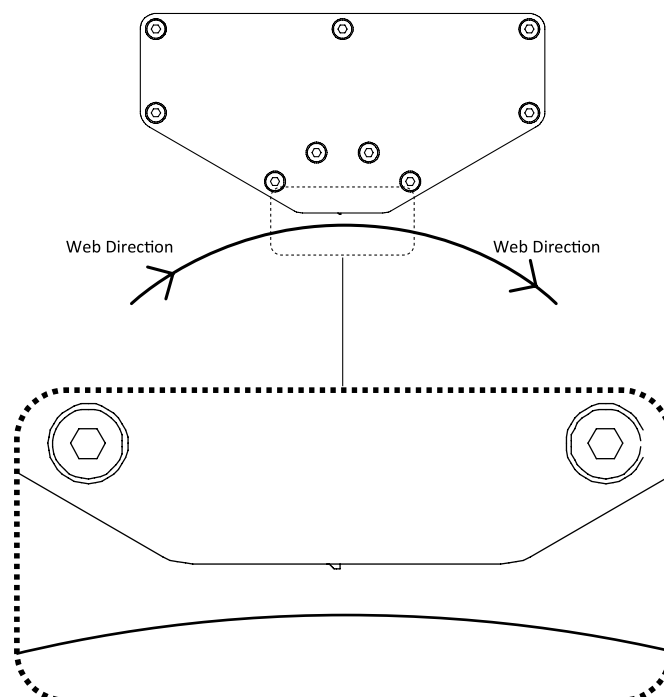

5.3.3. General Mounting Instruction

INFORMATION

The images below are for illustration purposes only and the style of your system may differ. Please refer to the Appendices for technical drawings, showing the mounting positions for each style of CyClean-R

Please follow the steps below for instruction on how to mount the CyClean-R manifold:

1. Locate the 4x M8 mounting holes in CyClean-R end plates

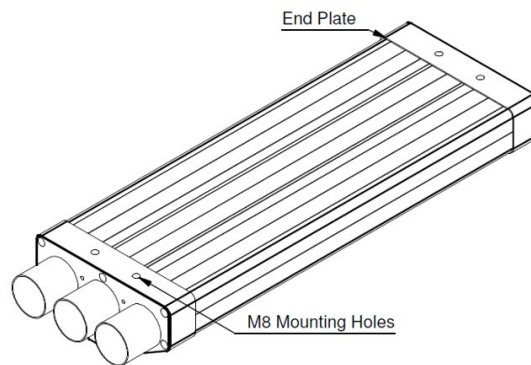

2. Fix the CyClean-R manifold with suitable M8 screws, so that it is positioned between 1-3mm from the surface of the web

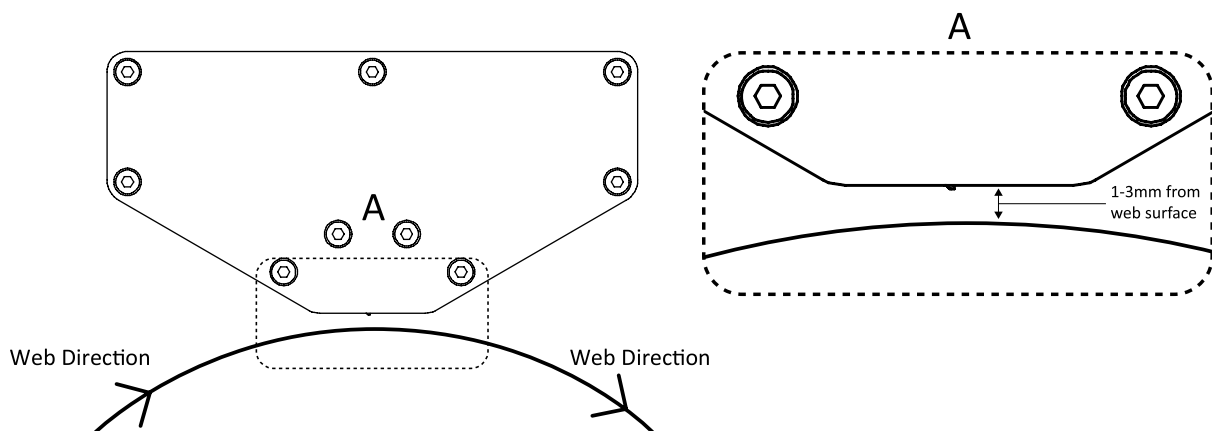

3. When installing CyClean-R manifold over web, ensure the direction of the web corresponds to the orientation of the pip on the CyClean-R extrusion

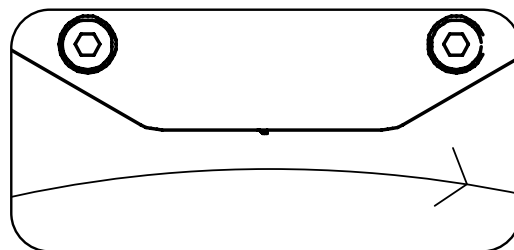

5.3.4. Fixed CyClean-R

Mounting Fixed CyClean-R up to 1300mm

Web widths up to 1300mm will be similar to the CyClean-R below. Web widths over 1300mm use a carapace, with alternative mounting options.

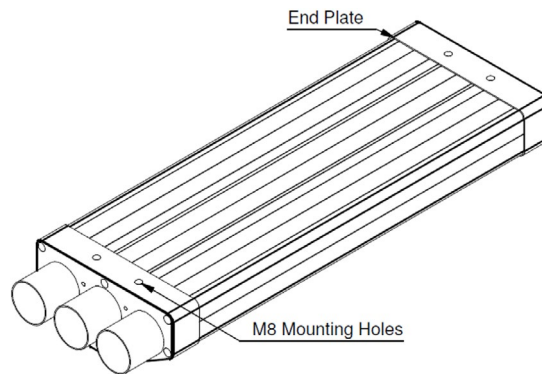
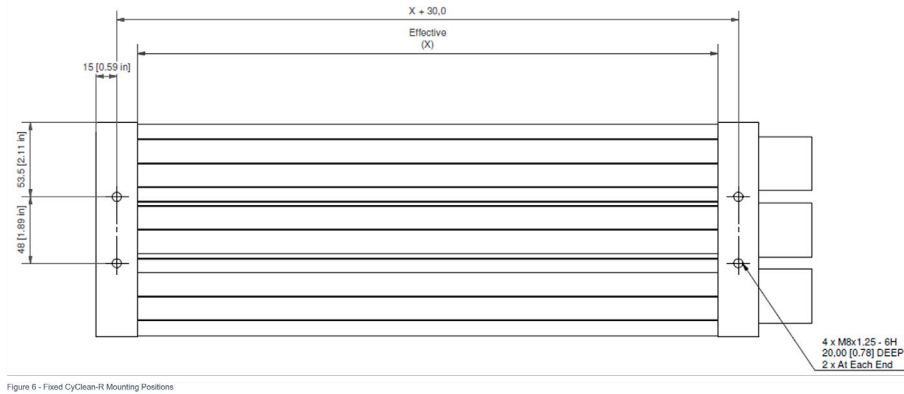

5.3.5. Fixed Carapace CyClean-R

Mounting Fixed CyClean-R Carapace

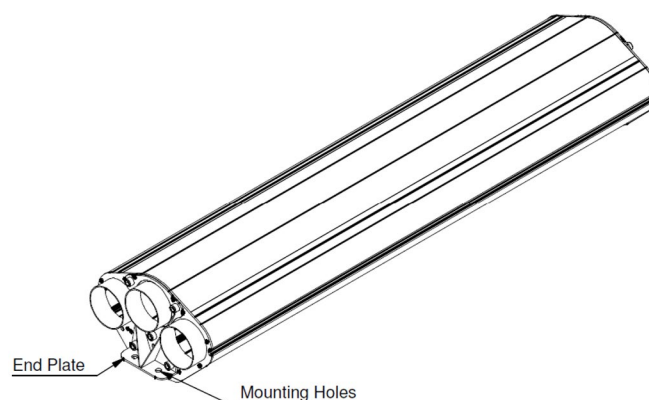
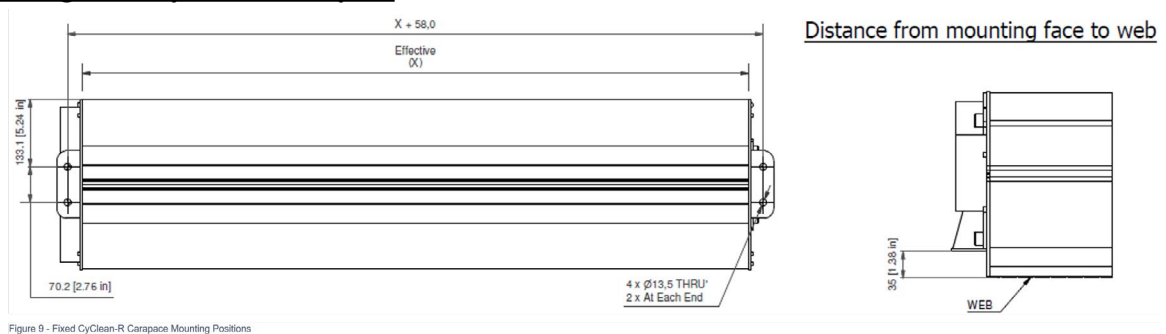

5.3.6. Pneumatic CyClean-R

This opening method is standard for systems suitable for a web width range of 200mm to 1200mm. This option can be installed so that the system opens up at any angle around a roller. The moving half of the head can be controlled locally or remotely to allow full line integration.

Mounting Point Pneumatic End Feed CyClean-R

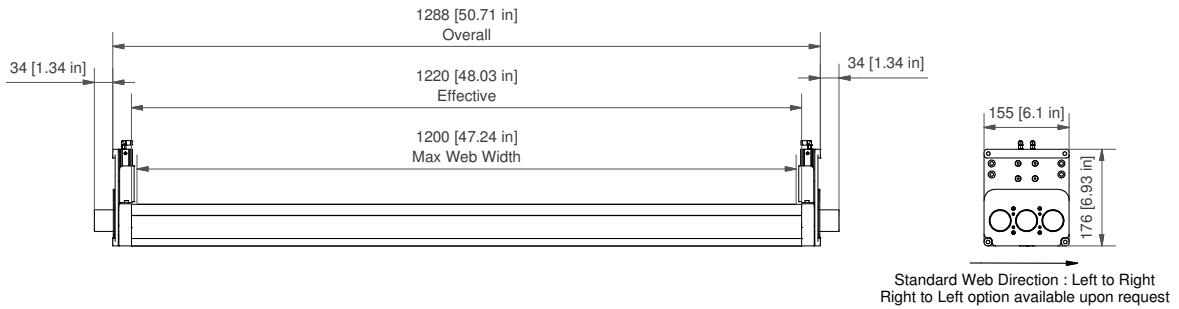

Mounting Point Pneumatic TAB-Feed CyClean-R

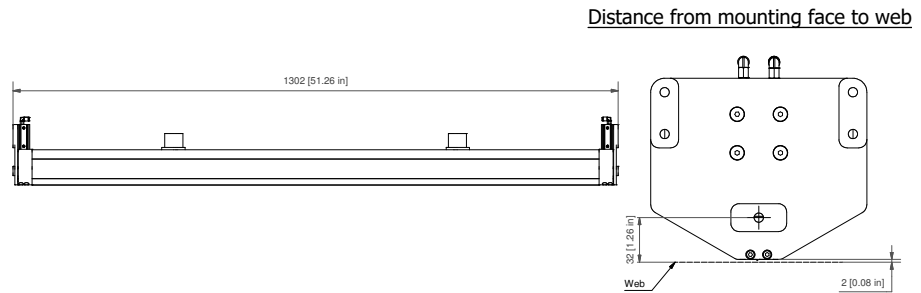

5.3.7. Pneumatic CyClean-R Carapace

This opening method is standard for systems suitable for a web width range of 1300mm to 4000mm. This option can be installed so that the system opens up at any angle around a roller. The moving part of the head can be controlled locally or remotely to allow full line integration.

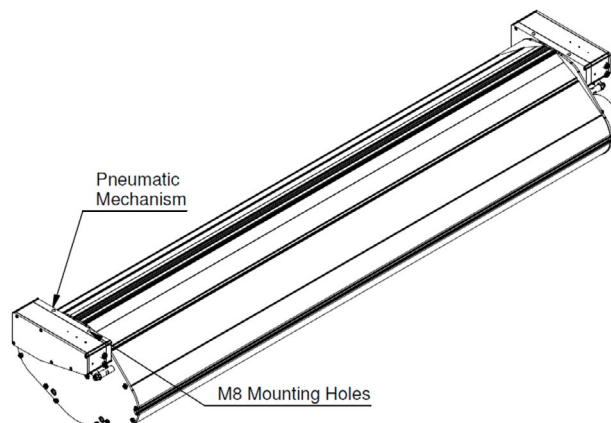
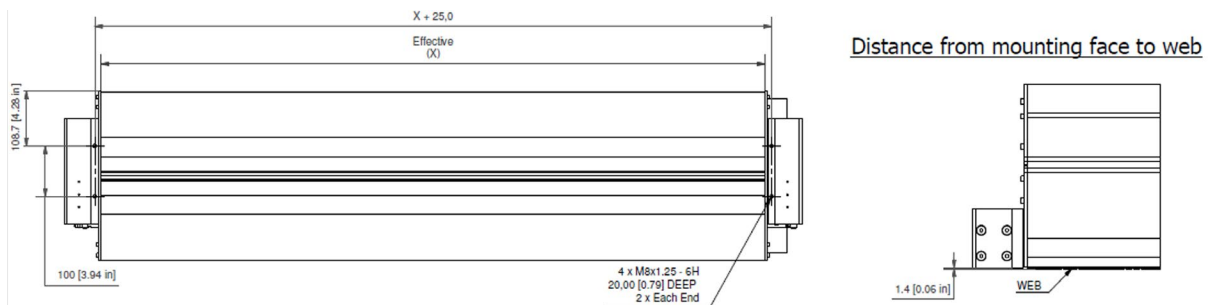

5.4. Pneumatic Connection

IMPORTANT

Installation of the CyClean-R system should only be completed by those with suitable qualifications.

Pneumatic CyClean-R systems are supplied with a pneumatic control box and a 5m length of 6mm blue/black dual core airline to connect the manifold to the pneumatic box. Meech does not supply airline to connect the pneumatic box to the main air supply.

Compressed Air Requirement

The CyClean-R system requires a compressed air supply to open and close the head unit. The compressed air supply should meet the following specification:

- 3 -7 bar (43-100psi)
- Clean and dry compressed air



Mounting Pneumatic Control Box

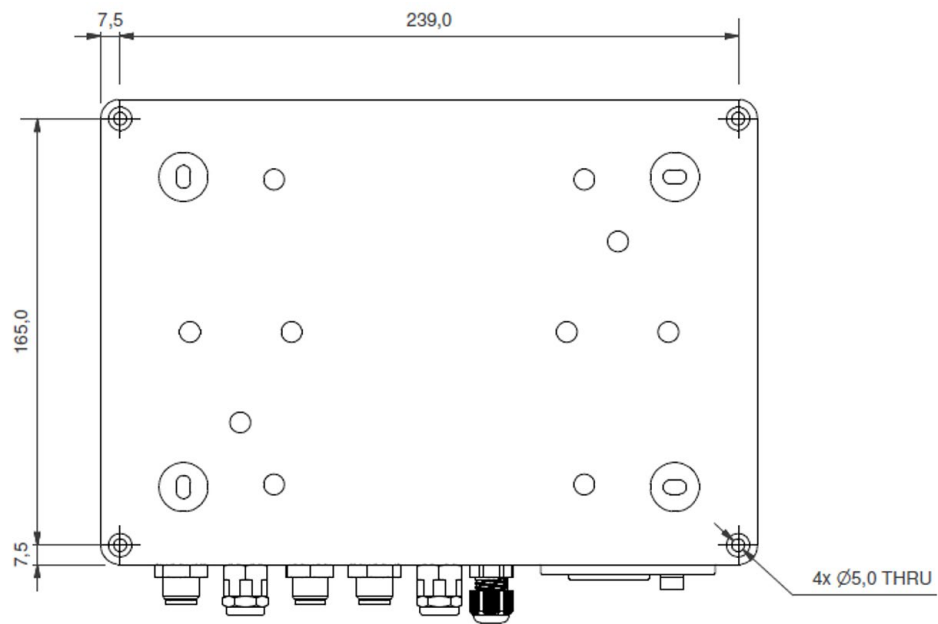

Connecting to Pneumatic Control Box

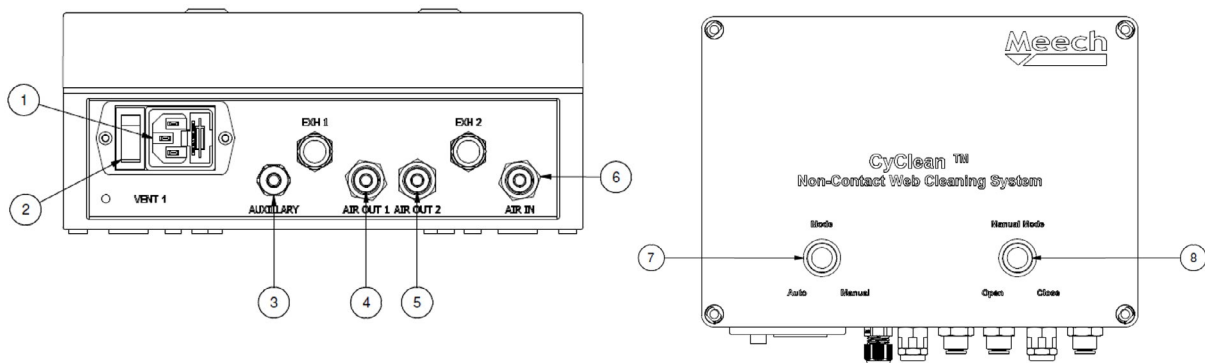

| Number | Description |
|--------|---|
| 1 | IEC Power Connection Socket, IEC Cable Supplied with Flying Lead |
| 2 | On/Off Switch |
| 3 | Auxiliary Gland |
| 4 | Air Out 1 (Blue Airline), Connection from CyClean-R 6mm Push-In Air Fitting |
| 5 | Air Out 2 (Black Airline), Connection from CyClean-R 6mm Push-In Air Fitting |
| 6 | Air In, Connection from Main Air Supply 6mm Push-In Air Fitting |
| 7 | Auto/Manual Button |
| 8 | Engage/Disengage Button |

WARNING

Compressed air can cause serious injury. It is important the air supply is not on or pressurised before connecting the main air supply. Ensure all air line between the manifold and pneumatic box is connected correctly before turning on air supply .

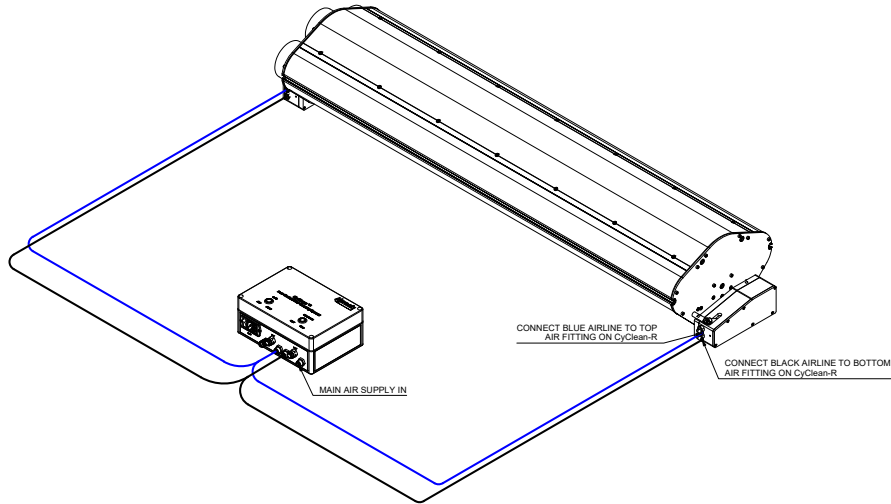

This opening method is standard for systems suitable for a web width range of 200mm to 1200mm. This option can be installed so that the system opens up at any angle around a roller. The moving half of the head can be controlled locally or remotely to allow full line integration.

Connecting Remote On/Off Signal from the Line

Connect external switch to spare terminal 1 and link to terminal 6 (leave existing wire in place) as shown in the image below and consult the wiring diagram at the end of this document.

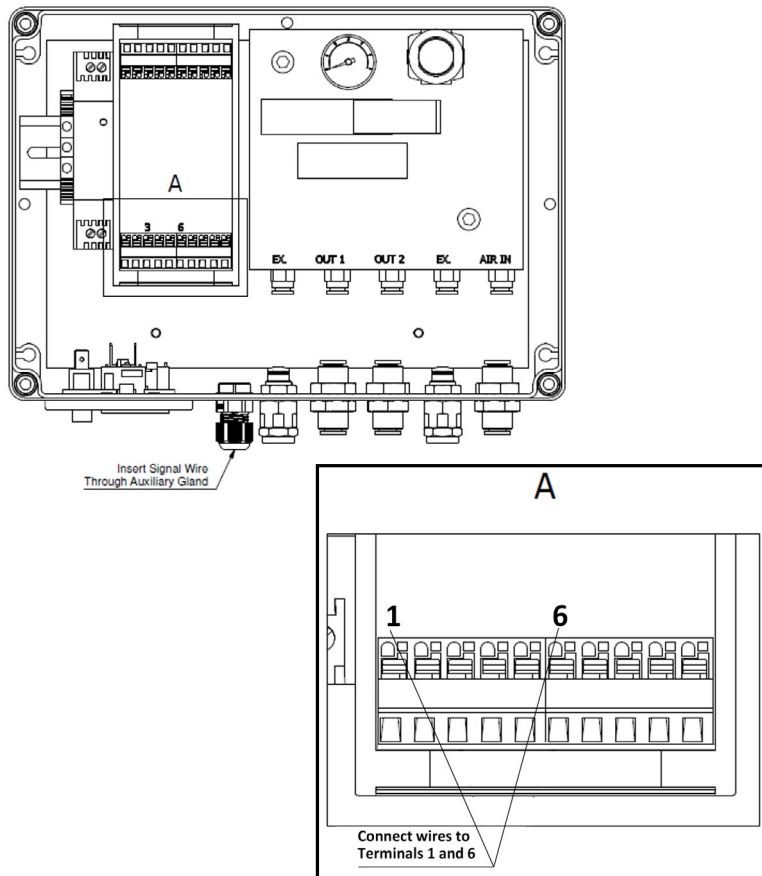

5.5. Positioning of 924IPS Bars

The 924 is a short to mid-range bar. Dependent on the application, the bar will be mounted between 20mm and 150mm from the target surface.

The bar should be mounted securely, using all the M4 T-bolts provided with the bar.

Correct positioning of the bar is vital for effective static control. There must be no metallic objects or obstruction between the bar and the material. The diagram shows the area that should be kept clear.

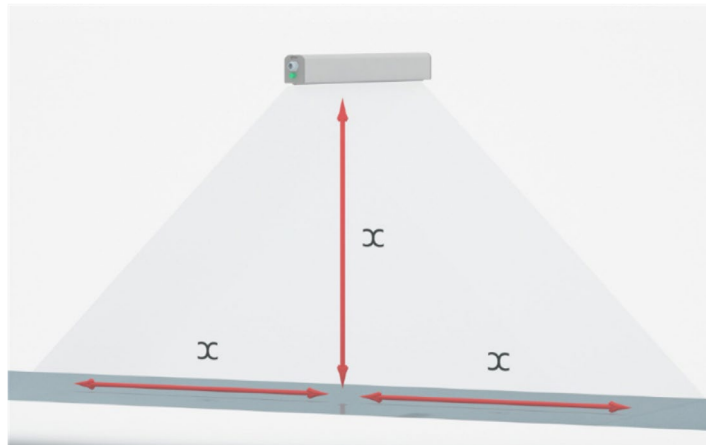

When installed at short range over a web or sheet, the bars must be positioned away from surfaces and rollers, as shown in the following diagram.

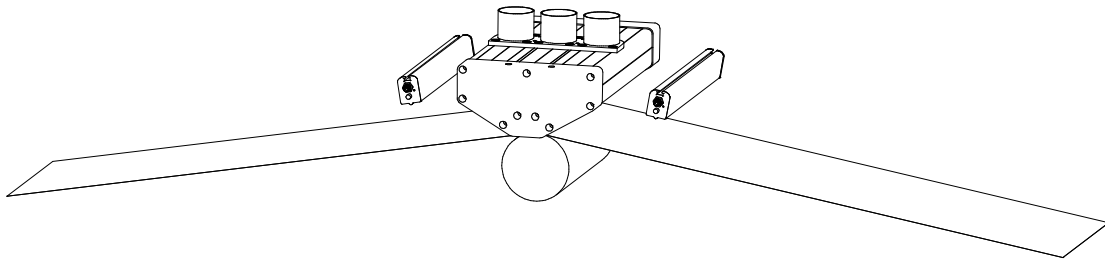

Your Meech distributor will be able to assist with questions regarding positioning of your equipment.

5.5.1. Electrical Installation

WARNING

The 924IPS requires a grounded 24V DC supply. The 0V line must be connected to ground. Failure to do so, will result in damage to the bar or the 24V supply and will void the warranty .

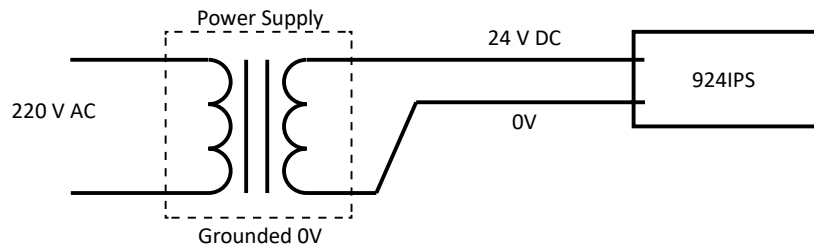

Connection to the 924IPS is via an industrial M8 4 Pin connector. With the following pin-outs:

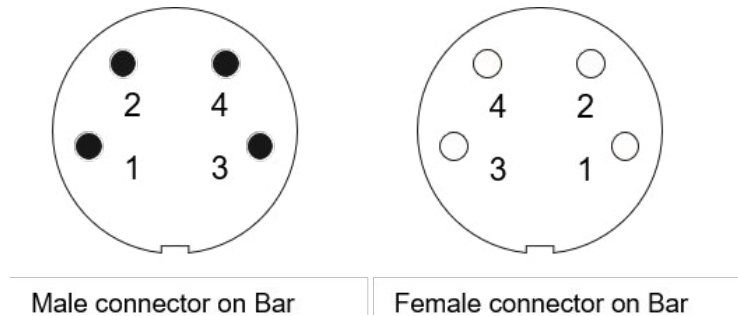

| Pin | Colour | Function Specification |
|-----|--------|---|
| 1 | Brown | 24V (21-27V) |
| 2 | White | Clean Pin and fault alert output 0V/24V |
| 3 | Blue | 0V/ Ground |
| 4 | Black | Fault alert output/ standby input |

5.6. Connecting to Power Supply

5.6.1. Connecting to Meech Power Supply

Meech 24V DC supplies are grounded internally. It is important that the mains connection offers a ground connection. Two-pin outlets without a ground connection must not be used.

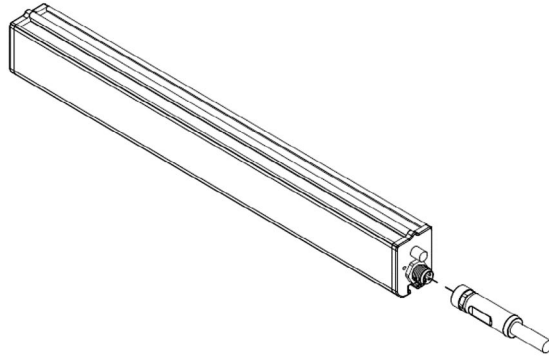

5.6.2. Connecting to Customer's Power Supply

It is the customer's responsibility to check that the 24V power supply they will be using is grounded.

The 24V supply should be protected with a 1 Amp fuse.

IMPORTANT

Ensure you have read and fully understand how to operate the Ionising Bars before use.

5.7. Ducting

5.7.1. Ducting Kits

IMPORTANT

Meech does not supply ducting with CyClean-R systems. This can be purchased separately.

Meech offers a standard ducting kit suitable for the system ordered. The kit comes in various lengths dependant on the CyClean-R web width. The kits offered as standard are specified below.

| Product Code | Description | Single Sided | Double Sided | Web Width |
|--------------|---------------------------|--------------|--------------|-------------|
| ACR-DKM-01 | 1m Flexible Ducting Kit | ✓ | | 0-600mm |
| ACR-DKM-02 | 1.5m Flexible Ducting Kit | ✓ | | 0-600mm |
| ACR-DKC-01 | 2.5m Flexible Ducting Kit | ✓ | | 601-1200mm |
| ACR-DKS-01 | 5m Flexible Ducting Kit | ✓ | ✓ | * |
| ACR-DKS-02 | 8m Flexible Ducting Kit | ✓ | ✓ | * |
| ACR-DKS-03 | 8m Flexible Ducting Kit | | ✓ | 2301-4000mm |

5.7.2. Connecting the Ducting

The CyClean-R manifold is designed with three pressure chambers, the two outer chambers are vacuum pressure and the central chamber is positive pressure.

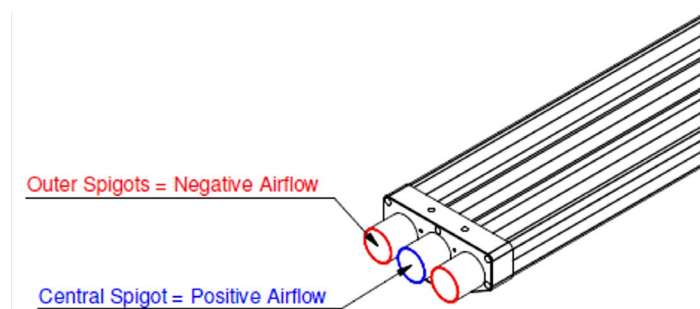

It is vital all ducting is connected to the correct chamber from the Air Handling Unit to the CyClean-R manifold.

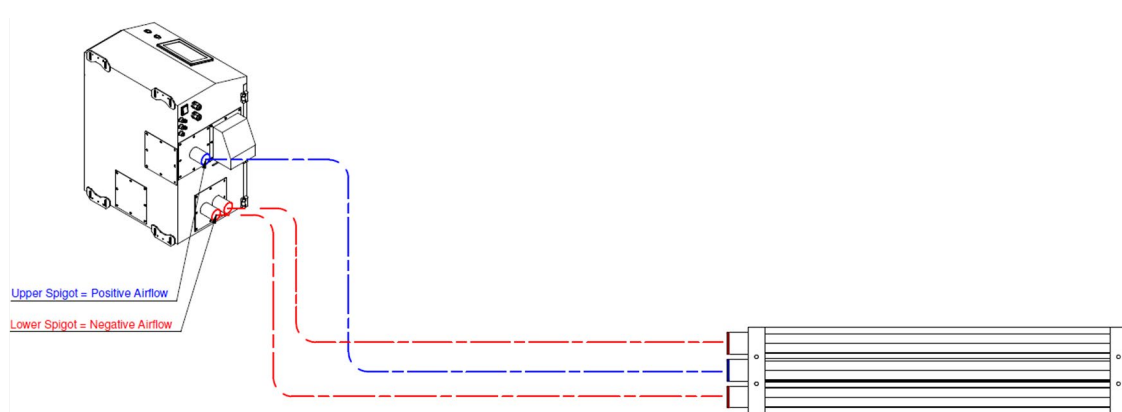

CAUTION

Ducting configurations will differ depending on CyClean-R system purchased. See appendices for detailed technical ducting layout drawings.

5.7.3. Securing the Ducting

CAUTION

Keep the smallest diameter ducting lengths as short as possible. It is important there is as few bends in the ducting as possible to avoid restrictions to the airflow.

All ducting kits supplied by Meech will include hose clamps, to secure the flexible ducting to the equipment.

1. Place the hose clamp over the flexible ducting and then slide the ducting over the spigot on the CyClean-R manifold.

WARNING

Ensure ducting is fully located over the spigot in which the ducting is being fitted. This will ensure no leaks.

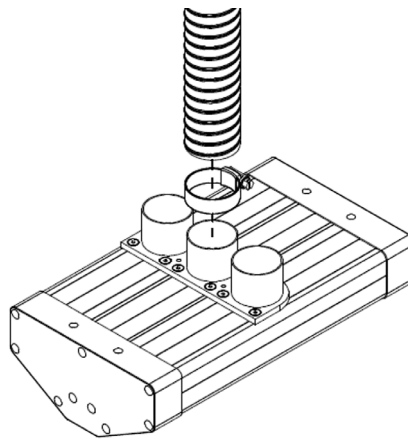

2. Secure hose clamp.

WARNING

It is important the hose clamp is torqued enough so that the ducting does not blow off under pressure.

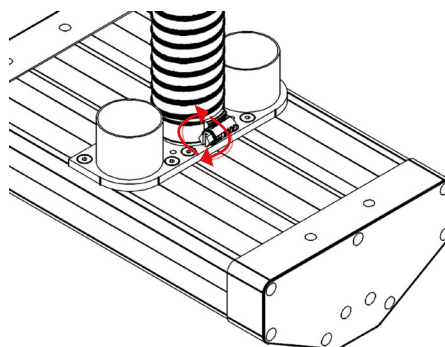

6. Operating the CyClean-R

6.1. Before Use

Before using the CyClean-R system it is important that you have read and fully understand this manual.

IMPORTANT

Testing of the system is recommended before it is used for full production

6.2. System Setup

The net airflow into either side of the CyClean-R head is adjusted by bleeding off a volume of the blowing (positive) airflow to create an airflow bias in favour of vacuum. Consult the AHU manual for full instructions of how to balance the airflows.

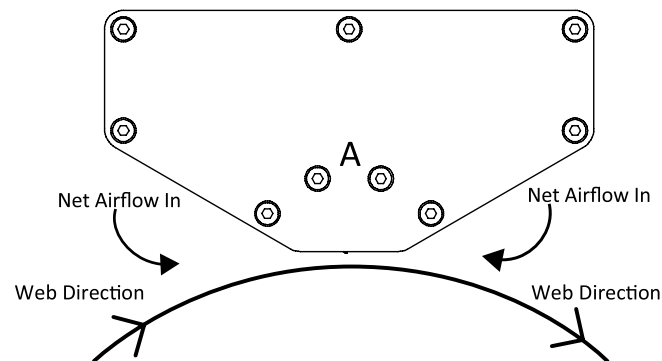

All CyClean-R systems are tested before leaving the factory. The CyClean-R is set up with a net inflow of air, with the vacuum set to 1kPa and the positive set to achieve this. This can be adjusted to achieve optimum cleaning results for the CyClean-R web cleaner.

The best cleaning results will be achieved when the system is set to have a positive airflow into the CyClean-R head, on both the web entry and exit sides (minimising the risk of any recontamination).

To adjust the pressure, follow the steps below:

1. Adjust the vacuum pressure using the the '+' or '-' symbols on the user interface.

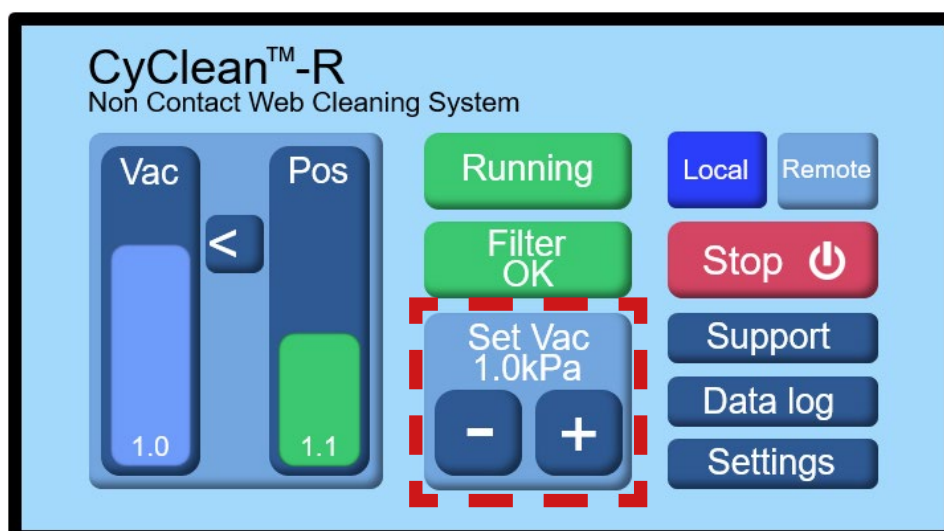

- Once the desired vacuum pressure has been set, the positive airflow may need to be bled off. This is done by adjusting the bleed valve on the rear of the Air Handling Unit. To adjust, loosen the knurled screw and slide the valve. Once the bleed valve has been set, ensure the knurled screw is tightened.

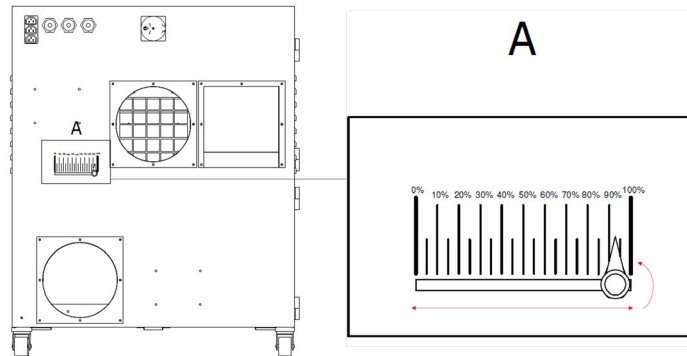

CAUTION

It is recommended that you monitor the system when it is first installed. If any problems are found, please stop using the CyClean-R system and contact Meech International or your local distributor.

6.3. Pneumatic CyClean-R

Operating Pneumatic Control Box

The pneumatic control box has two push buttons which are used to control the movement of the pneumatic cylinders on the CyClean-R manifold. Each button has a different function:

- Auto Mode** –When Auto Mode is activated, the button will be illuminated blue. The pneumatic control box can be connected to the users PLC, which can be used remotely to activate the pneumatic cylinders on the CyClean-R manifold. When in 'auto mode', the 'manual mode' button will be deactivated.
- Manual Mode** – When in Manual Mode, the CyClean-R pneumatics can be controlled by the use of the button. When the CyClean-R pneumatics are open the button will be illuminated green. In order to close the pneumatic cylinders, press the button again.

CAUTION

'Manual mode' button will not be effective when the control box is set to Auto Mode.

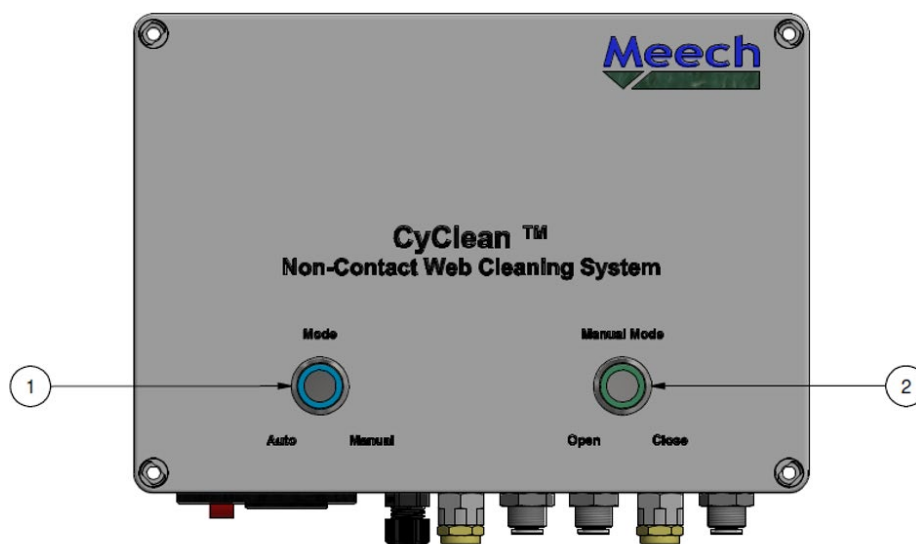

Adjusting Air Pressure

There is a pressure relief regulator valve inside the CyClean pneumatic control box. Adjusting this valve will restrict the air pressure that will be fed to the cylinders of the opening mechanism.

To adjust, see the following steps:

1. Remove the lid of pneumatic control box. A flat bladed screwdriver will be required to loosen the four screws.

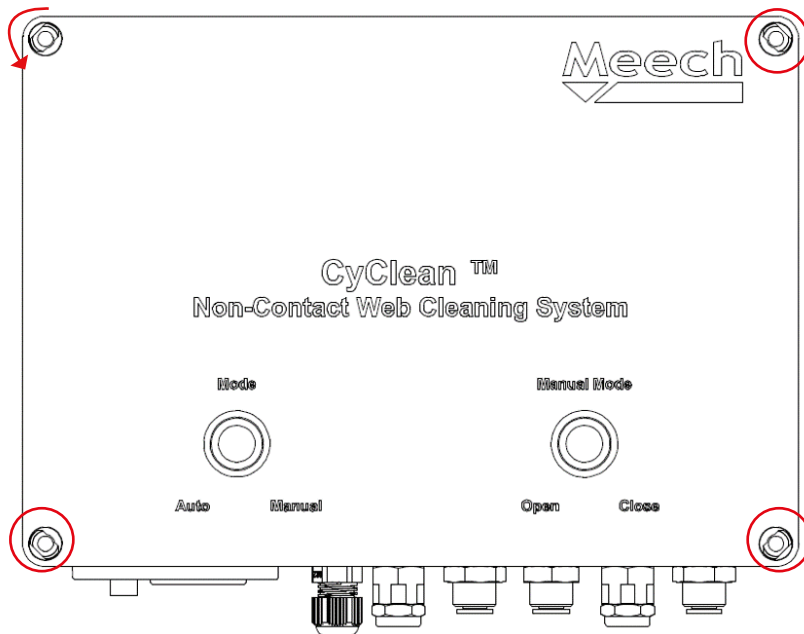

2. Locate the pressure regulator. To adjust, pull the valve up and rotate clockwise to increase pressure and anti-clockwise to release pressure. Once pressure is set, push the valve down until it clicks. The pressure is now set.

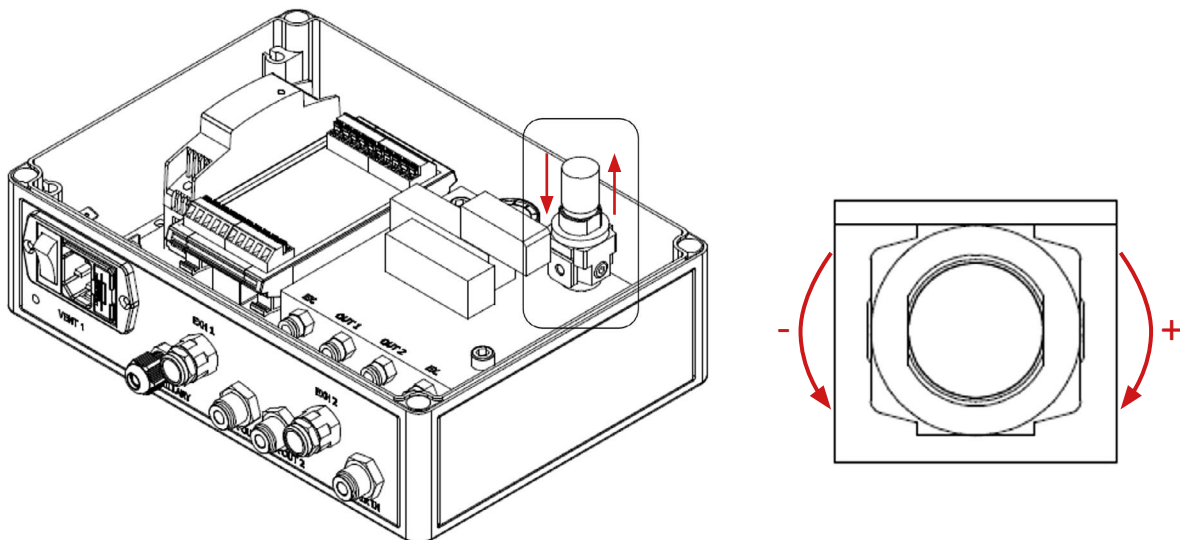

3. There is a pressure gauge next to the pressure regulator valve which displays the pressure set in Bar.
 - Detail A is the pressure regulator
 - Detail B is the pressure gauge

CAUTION

If you need to adjust the pressure relief valve, make sure that it is not adjusted to an excessive level. Excessive pressure may result in damage to your system.

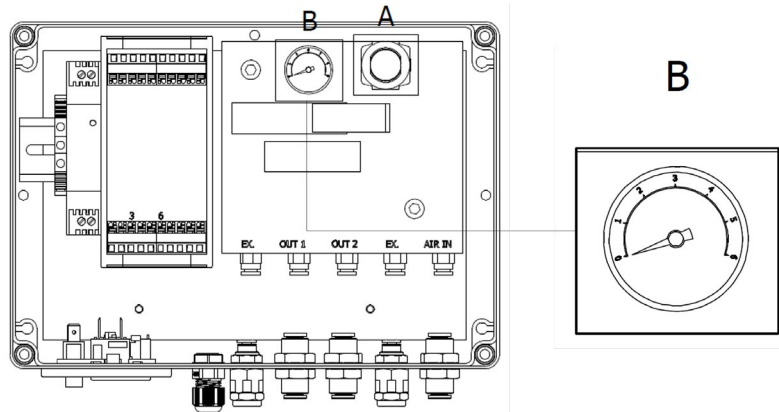

INFORMATION

This valve will have been set at Meech before your system was supplied.

Adjustment of Head Opening / Closing Speed

The speed/force at which the CyClean-R head opens and closes can be independently adjusted. This will be adjusted by Meech before your system is supplied so that:

- Open = medium to fast operation
- Close = slow speed

The speed can be adjusted using the 4 valves on the tubing to each of the cylinders.

IMPORTANT

When making any adjustment, it is very important that cylinders are adjusted at the same time to the same setting. Failure to do this may result in damage to your system and voiding the warranty.

CAUTION

It is recommended that the closing speed/force of the head is minimal, as this is a pinch point that could cause injury

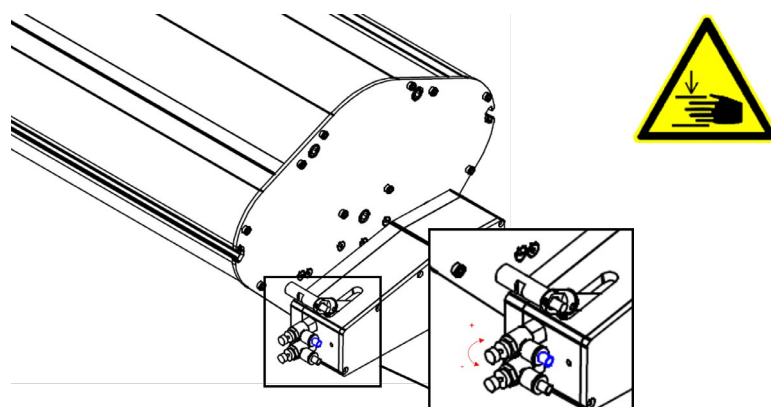

6.4. Commissioning

6.4.1. Initial Setup

The CyClean-R system is pre-set at Meech. This is a default setting that may need to be adjusted to achieve more efficient and effective cleaning results.

INFORMATION

Before using the CyClean-R for production, it is recommended an initial setup and test is carried out to achieve the optimum cleaning performance of the system.

When the CyClean-R has been set up, an initial test is recommended. This should be done by marking out a small section on the web and adding a small amount (approximately 10mg) of contamination, before passing the web through the CyClean-R manifold and 924IPS Bars.

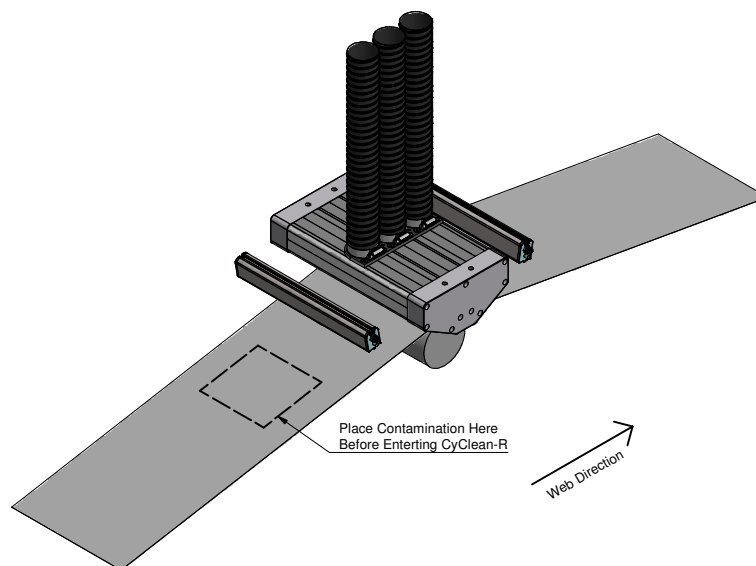

Once the web has been passed through the CyClean-R and 924IPS Bars, check the marked area for remaining contamination. If contamination is still present, adjustments may need to be made to enhance the cleaning performance.

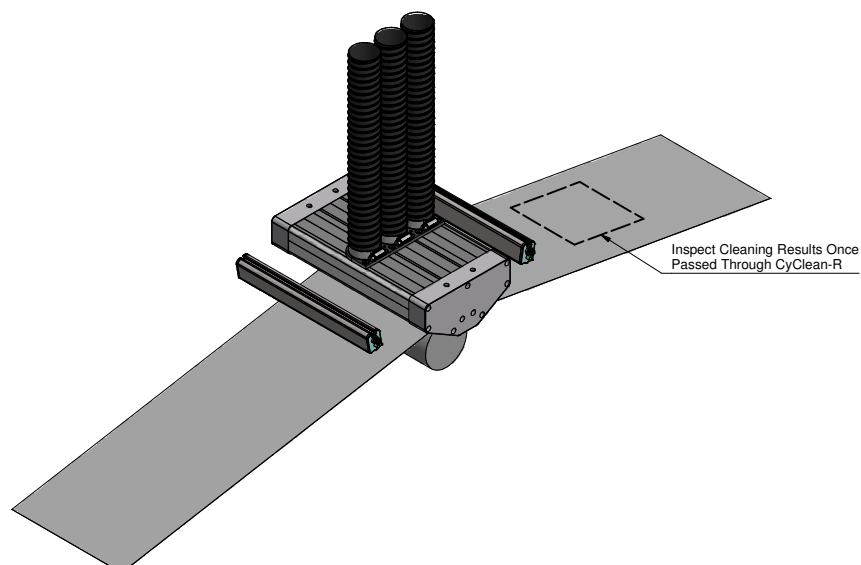

7. Troubleshooting

| Problem | Cause | Solution |
|-------------------------------|--|--|
| No blowing or vacuum pressure | Loose duct connection | Check all ducting connections are secure and that there is no damage. |
| | Duct layout | Check the ducting layout to ensure there are no tight bends. |
| | AHU fault | Check power is connected to AHU and that all isolators to the line are active (if used). Consult AHU manual for full operating instructions. |
| | Ducting manifold panel is not properly connected | Visually check the duct manifold and feel for air flow. Re-fit removable panel. |
| No Ionisation | Various | See the Meech fault finding guide for the Meech Model A924 DC ionising bars, which can be downloaded directly from the Meech website at www.meech.com |

If the problem being experienced is not listed above, or the remedy is unclear, please contact Meech International directly or your local Meech distributor.

8. Maintenance & Inspection

IMPORTANT

Always make safe the electrical and compressed air supplies before undertaking any maintenance work on the CyClean-R system.

8.1. Inspection

The system will perform without serious deterioration, giving many years of service, providing the following visual inspections are made weekly:

Head Unit

Check for any external damage and the alignment of the head unit. Wipe over all surfaces to remove any contamination. Inspect the cables from the ionising bars to the ionising power supplies are secure, free from damage and that they do not have any tight bends in them.

AHU Vacuum System

Listen for any sounds that are not 'normal' i.e., grinding or scraping. Regularly check the filter bag is in good condition and not full.

Filtration

Check that the filter warning lights on the AHU are not lit when running. Check for any external damage to the filter media, i.e. rips. Check to make sure the filter bag is not blocked.

Ducting

Visually inspect the ductwork, look for any loose sections or holes. Check to make sure the ducting is not blocked.

8.2. Maintenance

IMPORTANT

Maintenance should only be completed on the CyClean-R system by those with suitable qualifications.

Ionisation Equipment

INFORMATION

For detailed instruction, please consult the equipment's operating manual.

Ionisers require periodic cleaning. During normal operation, dirt will build-up on the emitter pins and upon the body of the ioniser. This will cause a reduction in performance.

Typically, weekly cleaning is sufficient. However, equipment used in some heavy contamination areas, such as gravure printing or where plastic fumes are present, may require daily cleaning. Equally, in a Class 100 area, cleaning may only be required on a monthly basis.

Advanced systems with performance monitoring, e.g. 977CM and 904CM, will alert the operator to the need to clean the equipment before performance drops to an unacceptable level. Before cleaning, ensure that the equipment is switched off.

Emitter pins can be cleaned very effectively with a brush. A dry toothbrush is ideal.

Ionising bars will need periodic wiping to clean grey deposits from the surface of the bar. A cloth moistened with a small amount of IPA or methylated spirits is recommended.

Should you have any additional questions regarding the maintenance of Meech equipment please contact Meech International directly or your local Meech distributor.

Fault Finding

Fault finding guides for the Meech Model A924 DC ionising bars can be downloaded directly from the Meech website at www.meech.com

For further fault-finding guidance please contact Meech International directly or your local Meech distributor.

AHU

Consult the AHU manual for full installation and operation instructions.

9. Spare Parts

It is recommended that only Meech spare parts are used in your CyClean-R system. The use of non-Meech parts may invalidate your warranty.

For details of spare parts, please contact Meech or your nearest Meech distributor.

Please quote the serial number of your CyClean-R system when ordering spare parts.

10. Technical Specification

| | |
|--------------------------------|----------------------------------|
| Maximum Web Speed (Web Driven) | 600mtrs/min, 1968ft/min |
| Maximum Web Width | Up to 9000mm, 354.33" |
| Duct Connections * | Fixed position 40mm & 100mm Ø OD |
| Static Control | 2 x 924IPS DC Bars |
| Mounting | 4x M8 x 16mm holes |

11. Repairs & Warranty

The CyClean-R is warranted by Meech Static Eliminators Ltd to the original purchaser against defects in material and workmanship for one year after purchase. Should any malfunction occur, please return the system directly to Meech Static Eliminators or your local distributor. All products returned to the factory MUST be accompanied by a return authorisation number and must be shipped prepaid. For prompt service, ship the unit to the factory with the return authorisation number shown clearly on the label. Be sure it is well packed in a sturdy carton with shock absorbing material.

Include a note stating the nature of the problem as specifically as possible, and also include instructions for returning the unit to you. We will pay one-way return surface shipping costs on any repairs covered under the warranty.

Field repairs should never be undertaken. Attempts by unqualified personnel to repair the unit will invalidate the warranty.

12. Technical Drawings

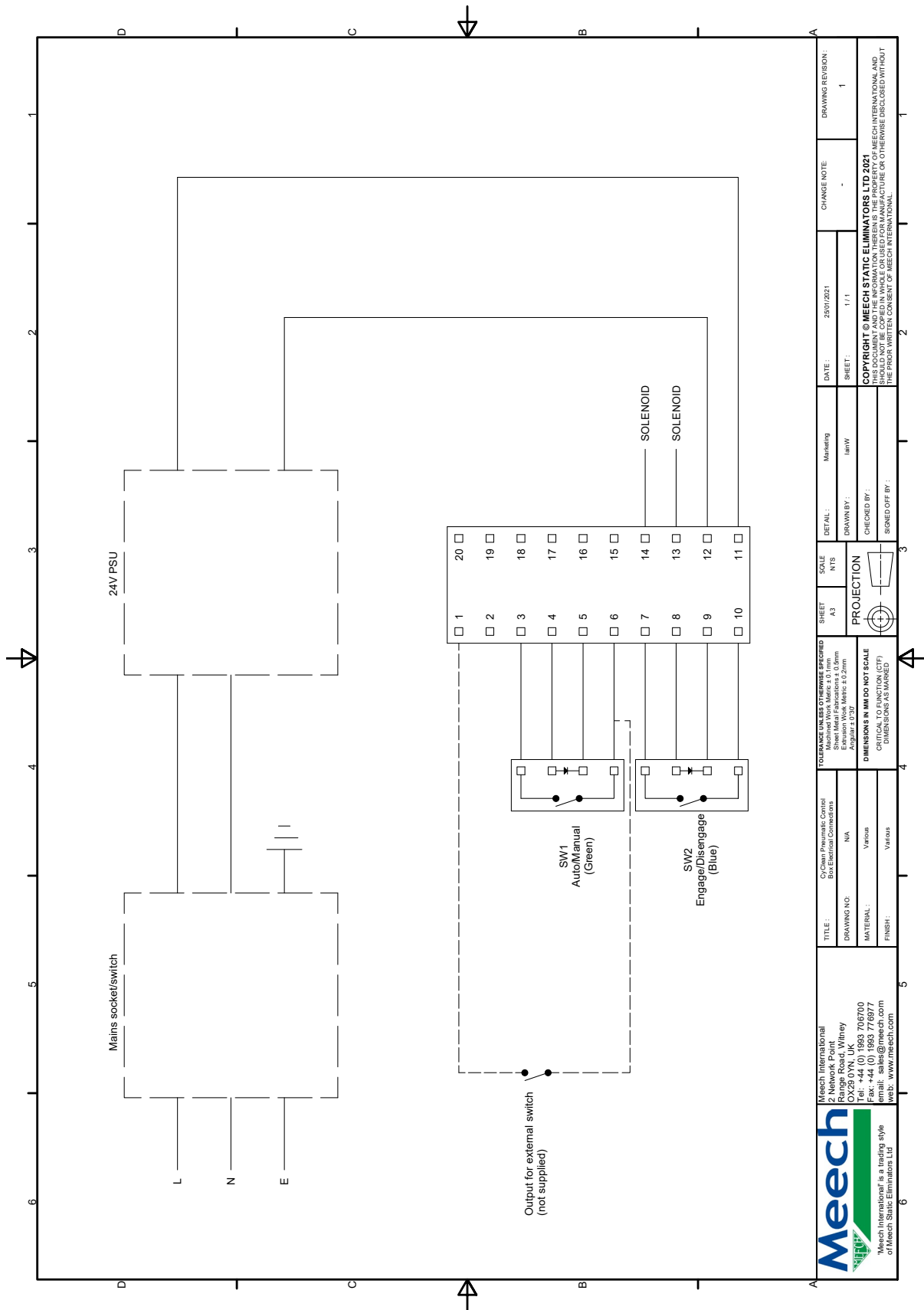

Meech International

2 Network Point
Range Road
Witney, Oxfordshire
OX29 0YN
United Kingdom
Tel: +44 (0)1993 706700
Email: sales@meech.com

Meech Static Eliminators USA

1298 Centerview Circle
Akron, Ohio 44321
United States
Tel: +1 330 564 2000
Fax: +1 330 564 2005
Email: info@meech.com

Meech Static Eliminators (Shanghai)

7G, 7F, LP Tower
#25 Xianfeng Road
201103 Shanghai
China
Tel: +86 400 820 0102
Fax: +86 21 6405 7736
Email: china@meech.com

Meech Shavotech

29/2, Kharadi
Off Pune-Nagar Road
Old Kharadi Mundhwa Road
Pune: 411014, Maharastra
India
Tel: +91 (0)703 093 8211 / +91 (0)741 000 4817
Fax: +91 (080) 28395963
Email: india@meech.com

Meech Elektrostatik SA

Kaiserbaracke 166
B-4780 St. Vith
Belgium
Tel: +32 (0)80 670 204
Fax: +32 (0)80 862 821
Email: mesa@meech.com

Meech International (Singapore)

7 Temasek Boulevard
12 - 07 Suntec Tower One
Singapore
038987
Tel: +65 65918859
Email: singapore@meech.com

Meech CE

Gábor László utca 2
Budapest 1041
Hungary
Tel: +36 1 7977039 / +36 30 2803334
Email: ce@meech.com



View and save a digital version of this operating manual by following the QR code or visiting www.meech.com/downloads:

